

## Stereo Mono Switchable Shotgun Microphone for Camera



With included accessory WSJ-10

- Switchable very sharp mono-shotgun and stereo microphone
- Very short length (210.5mm) and light weight (170g)
- Using PPS diaphragms, it maintains high durability and quality even in high humidity environments
- By use of a specially designed suspension holder, it can isolate camera motor noise in camera mount use
- Basic design is M-S, but includes M-S to L-R circuitry, and allows a direct L-R signal

The CMS-10 provides extremely high-resolution audio to match today's advanced picture quality. This versatile microphone is switchable between a very sharp directional Mono and rich Stereo in environmental imaging.

Unlike conventional shotgun microphones, the CMS-10 uses a unique second-order pressure gradient design, enabling precision directional response through multiple cardioid elements in a front-back array. The capsules combine line microphone performance and second-order gradient response in a single compact system.

Stereophonic localization depends primarily on signal accuracy and channel separation in the 400Hz to 3kHz range. Pattern control of the CMS-10 has been optimized in this range. Very low and very high frequency response has been optimized along the frontal axis so that the "target" on-axis sounds are clearly delineated.

## <Specifications>

Directivity	Mono = Super Cardioid Stereo = Hyper Cardioid (L-R Outputs)
Transducer	DC biased condenser
Frequency range	150Hz - 20kHz
Sensitivity (nominal at 1kHz)	STEREO 50mV/Pa ( -26dB,0dB=1V/Pa) MONO 32mV/Pa ( -30dB,0dB=1V/Pa)
Equivalent noise level (A-weighted)	STEREO 20dB-A , MONO 22dB-A
Max SPL (1% THD)	120dB SPL
Output impedance at 1kHz	240Ω
Powering	+48±4V phantom X 2ch
Stereo angle	127°
Current consumption	less than 4mA / ch
Weight	170g
Dimensions	211mm X 27.8mm (metal mesh part diameter) 26.5mm (Suspension cylinder diameter) 19mm (grip diameter)
Surface finish	matte black
Connector	Cable direct out from the microphone, 30cm, XLR-5M
Included Accessories	WSJ-10 Short fur Softie windjammer Suspension cylinder set

## <Dimensions>

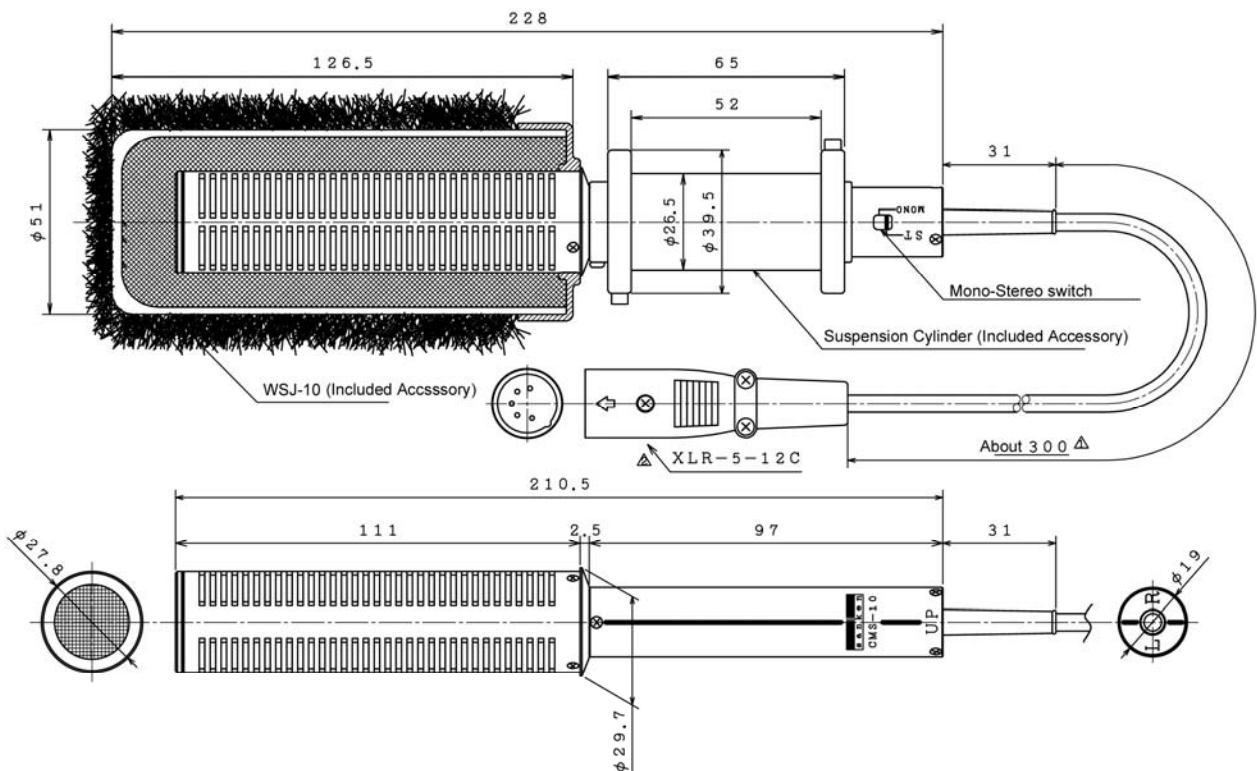

<Frequency Response>

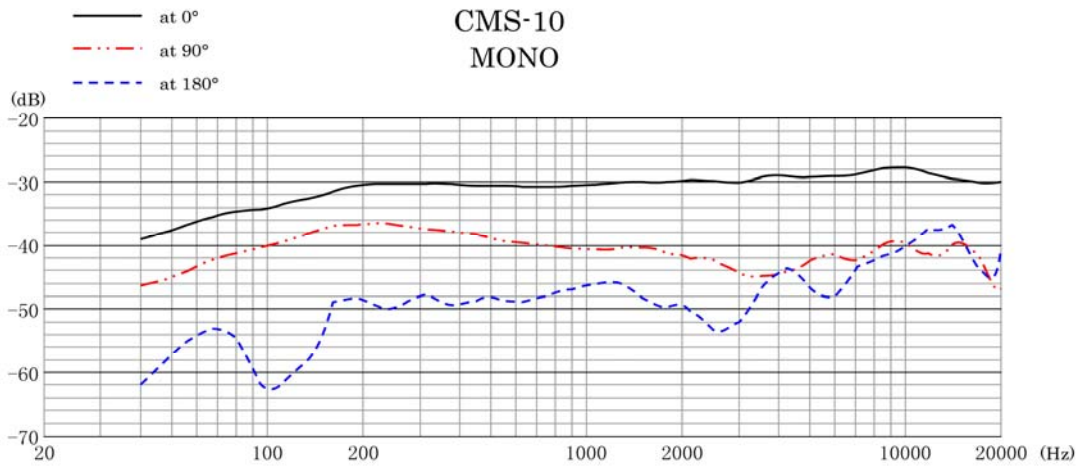

<Polar Pattern>

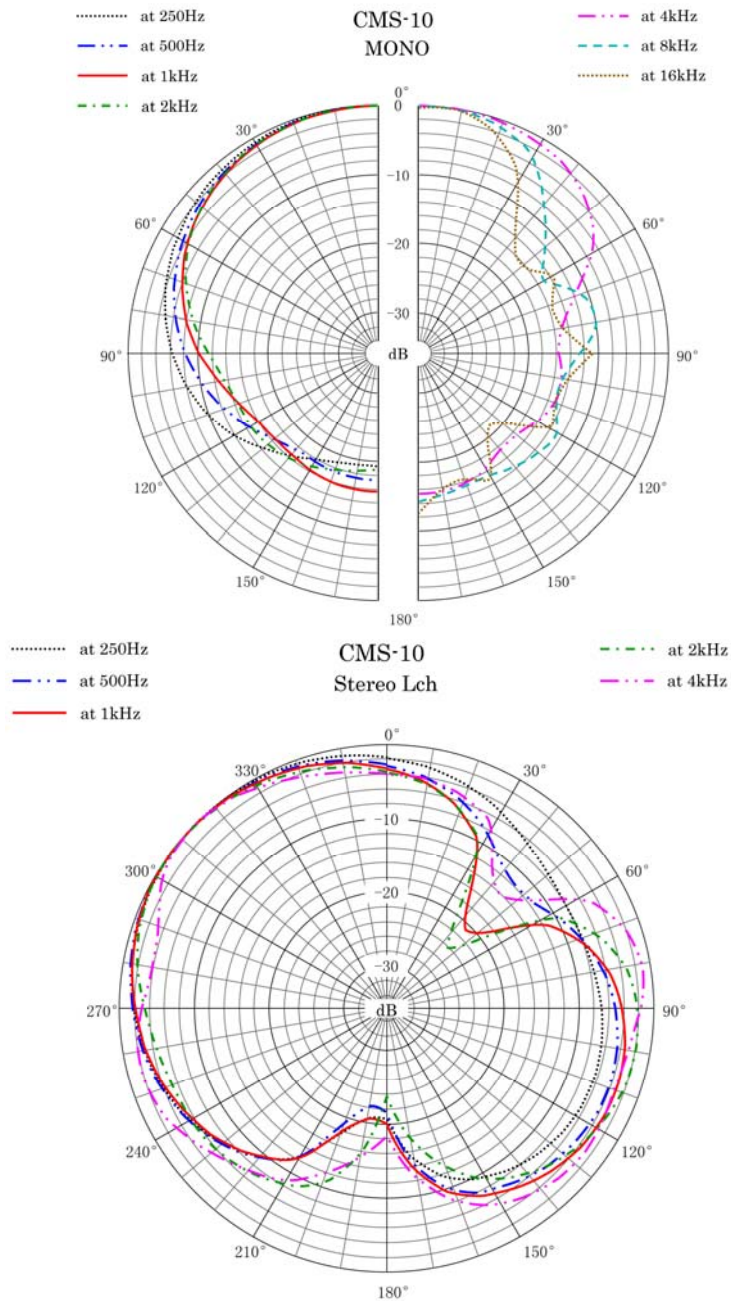

< Optional accessories >

**WSJ-10**

Softie windjammer



**Suspension  
cylinder set**



**CB-485II**

Phantom PSU  
One 6LR61 used  
2ch IN/OUT  
XLR5Pin M,F



**Doughnut rubber  
ring set**



**SC-532 / 0.3 , SC-532 / 1.8**

XLR-5F to two XLR-3M "Y"  
cable

**SC-551 / 0.3 , SC-551 / 1.5**

XLR-5F to XLR-5M cable

Specifications are subject to change without notice

**SANKEN MICROPHONE CO., LTD.**

2-8-8 Ogikubo, Suginamiku, Tokyo 167-0051 Japan

Phone: +81 3 3392 6581 FAX: +81 3 3393 2055 [www.sanken-mic.com](http://www.sanken-mic.com)